

KM0623WT

Dynamic Compact Combi Oven
Electric, 6 x 2/3 GN

Product Information

- Compact unit at only 519mm wide (30% less space required than traditional ovens)
- Highly efficient instant steam injection oven
- Controlled humidity in the cooking chamber
- Innovative touch screen interface
- One Touch function for easy, icon controlled cooking
- Over 120 pre-set cooking programs, 1,000+ additional programs - 9 phase memory
- Automatic, adaptive cooking, rack control, regeneration, sous vide and smoking programs
- Easy Service function and Recipe tuner as standard
- 3-speed inverter controlled fan for increased precision, control and reliability
- LED lighting for superior cavity illumination
- USB connection and core probe
- Oven cleaning system with liquid, via intergrated dispenser
- Left hand hinge door option available
- All Mini Touch ovens are supplied with either the Standard or Reverse Osmosis Filtration system
- **24-month warranty (Terms and conditions apply)**



Specifications:

Standard Filter	KM0623WT.SF
Reverse Osmosis	KM0623WT.RO
W x D x H (mm)	519 x 690 x 792*

*Dimensions do not include water filtration system

Weight	77kg
Capacity	6 x 2/3 GN Pans

Total Connected Load 4.7kW / 15A circuit*

Electrical Connection 3Ø+N+E 415VAC / 50Hz
L1=10.4A / L2=0A / L3=9.2A

*Circuit required to be determined at installation by a qualified electrician.

Cold Water Connection 3/4 BSP
300-350 kpa
Min 10°C - Max 30°C

Water Quality Requirements

Hardness	60-100ppm
TDS	<100mg/L
Cl Chloride	<32mg/L

Legend:

- A Electrical Connection
- B Steam Generation Water Inlet 3/4" BSP
- C Wash System Water Inlet 3/4" BSP
- D Drain Connection 40mm
- E Humidity Vent
- F Detergent & Rinse Aid Inlet

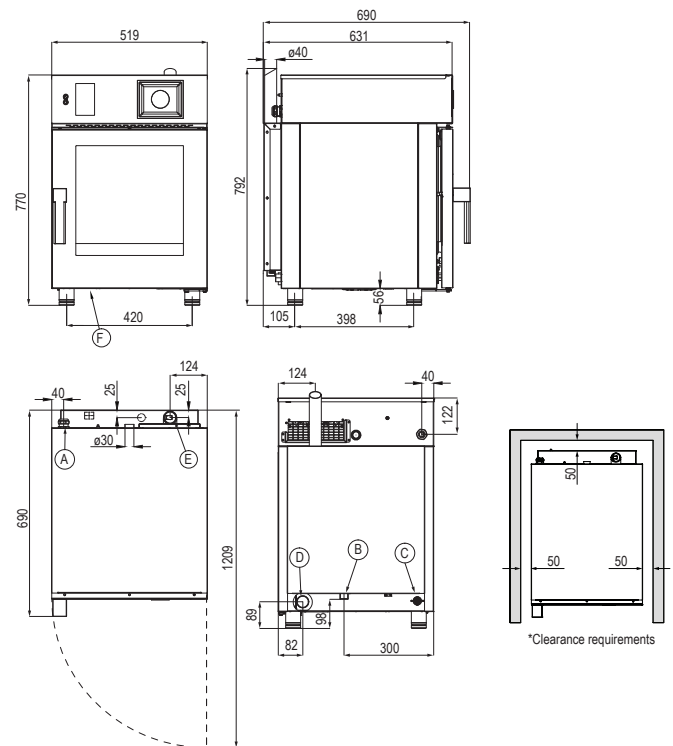

Heat Source: 500mm clearance from an external heat source is required in order to protect the oven control components. For clearances under 500mm, it is mandatory for Stoddart heat shields to be fitted while still maintaining a minimum clearance of 50mm to allow access to the unit. Failure to adhere to minimum clearances may void the oven warranty or add service costs due to lack of access.

Non-Heat Source: 50mm clearance from a non-heat source to allow access to the unit.