

DATA SHEET

Zanoli Ercolina Plus 22 Manual Dough Divider Rounder - 22 portions | 60 - 220g Portions

4AR0537



Build

- Manually operated dough portioning and rounding machine capable of producing up to 2,600 dough balls per hour with 22 portion sizes ranging from 60 to 220 grams.
- Accommodates dough loads from 1.3 to 4.8 kg, suitable for various types of dough products.
- Combines manual movements for pressing, cutting, and shaping with an automatic oscillating plate for rounding, providing easy of use and durability.
- The pressing phase utilizes a robust counterweight lever that the operator pulls down, ensuring even distribution and pressing of the dough inside the basin. This mechanism provides the necessary force for consistent results
- The cutting phase is activated by engaging a knife lever, allowing the machine to divide the dough into 11 identical portions, ensuring precise accuracy in portion sizes for consistent baking results.
- The shaping phase is optimized by a manual dial that allows operators to easily adjust the chamber height, accommodating various dough weights and volumes to create the ideal environment for smooth, blemish-free rounded balls.
- The rounding process is activated by pulling a lever, which engages the oscillating plate. This mechanism rapidly shapes the dough into perfectly spherical balls, streamlining the final stage of dough preparation.
- Constructed from an electro-welded painted steel chassis and exterior panels for enhanced resilience and durability
- Features stainless steel pressing plates and cutting blades for long-lasting performance
Inner cover surfaces and presses made from food-safe polyethylene (PE500) enhance hygiene and safety in food preparation.
- Includes a ring made of aluminum with chemical nickel-plating for extra strength and durability.
Basins made from anticorodal aluminum MG5 with anodizing for enhanced strength.
- Ideal for both small pizzerias and large bakeries, optimizing dough preparation and ensuring perfect results consistently as it transforms a time-consuming task into a quick, efficient process, even for untrained staff.



DATA SHEET

Zanoli Ercolina Plus 22 Manual Dough Divider Rounder - 22 portions | 60 - 220g Portions

4AR0537



Technical specifications

External Size

External Width	610mm
External Depth	680mm
External Height	2050mm

Weight

Net weight	180 kg
package weight	*

Connection requirements electric

Electrical connected loads	1.1kW
Voltage	415 V
Plug Supplied	No
Cable Length	*
Plug Type	Lead only

Environment

Temperature	0 - 40 °c
Maximum humidity	95% without condensation
Noise	< 70 decibel

Technical Fixtures

Dough Weight	1.3 - 4.8kg
Divisions	22
Portion Size	60 - 220g
Production Capacity	2600 p/hr
Head Diameter	Ø 400 mm

Warranty

2 Year Warranty	2 years parts and labour
-----------------	--------------------------

**Subject to a preventative maintenance plan*

We reserve the right to alter specifications without notice.

DATA SHEET

Zanoli Ercolina Plus 22 Manual Dough Divider Rounder - 22 portions | 60 - 220g Portions

4AR0537



Work Cycle

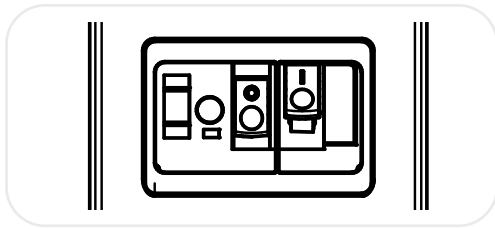

Step 1 - turn on

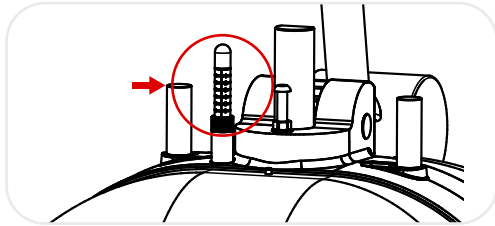

Step 2 - Adjust the weight regulating rod according to the desired dough weight. The regulating rod position determines the volume of the forming chambers, so it is regulated according to the weight of the dough that is to be cut. Since the correct adjustment depends on the dough consistency, regulating is a matter of experience. If the final volume of the forming chambers is too small, the balls of dough will be damaged. If the volume is excessive, the balls of dough will not be sufficiently formed.

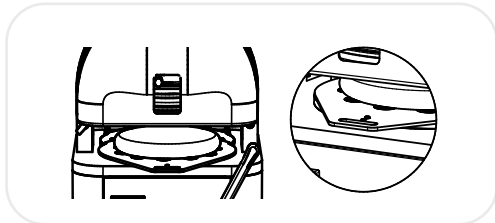

Step 3 - Insert the plate with the weighed dough inside the machine.

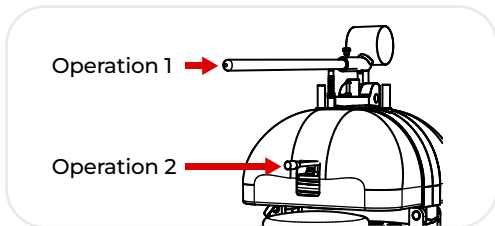

Step 4

(Operation 1) Lower the pressure handle and press it, thus compressing the dough. Once the pressing operation has been completed, do not lift the handle but keep it in that position.

(Operation 2) Cut the dough, pushing the dividing handle to the right; when this operation is performed, the blade will be released: lower the handle further, as far as it will go, to ensure that the dough has been completely cut.

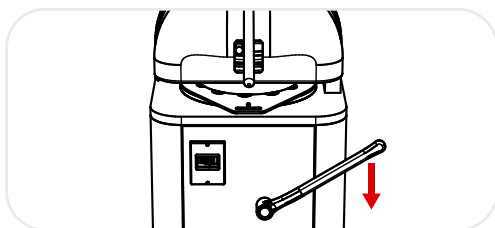

Step 5 - To start forming, slightly lower the forming handle. The moulding operation continues as long as the handle is down. The optimum forming time is established by experience and depends on the consistency of the dough.

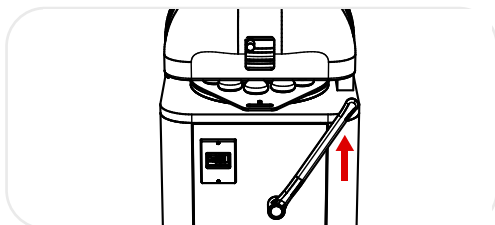

Step 6 - When the rounding phase is finished, return the forming handle to neutral position (wait until the forming plate stops), then raise also the pressure handle and return it to neutral position.

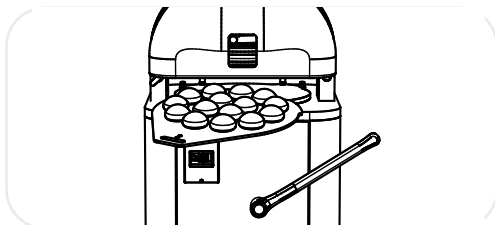

Step 7 - Extract the forming plate with the rounded pieces.

We reserve the right to alter specifications without notice.

DATA SHEET

Zanoli Ercolina Plus 22 Manual Dough
Divider Rounder - 22 portions | 60 - 220g Portions

4AR0537

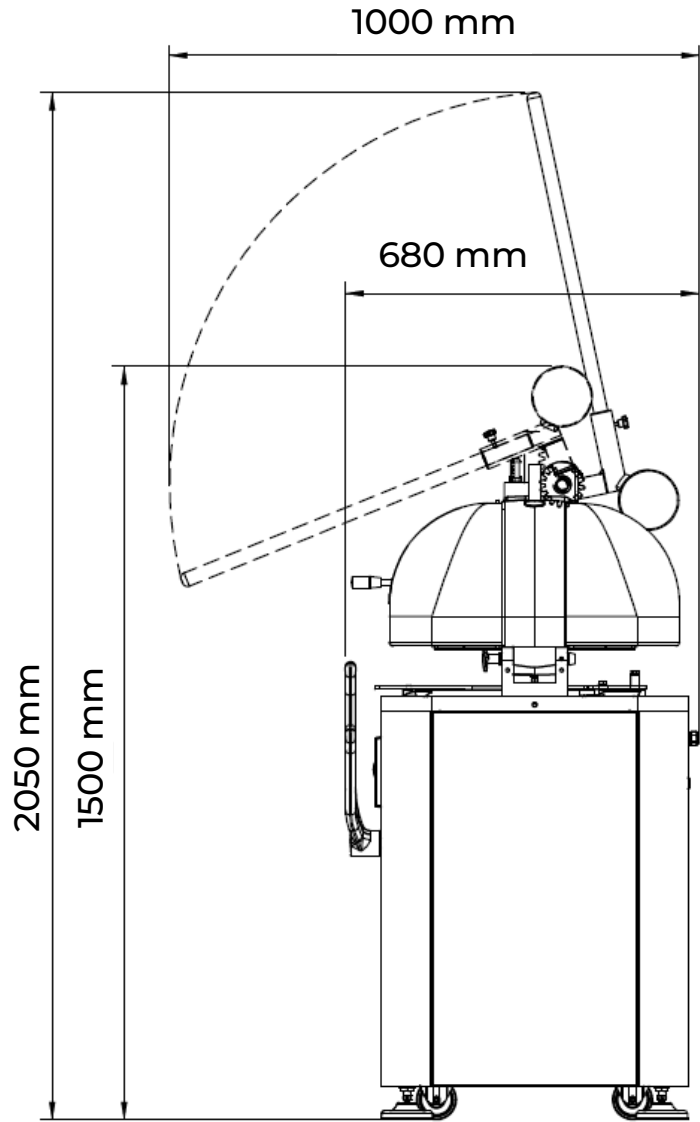
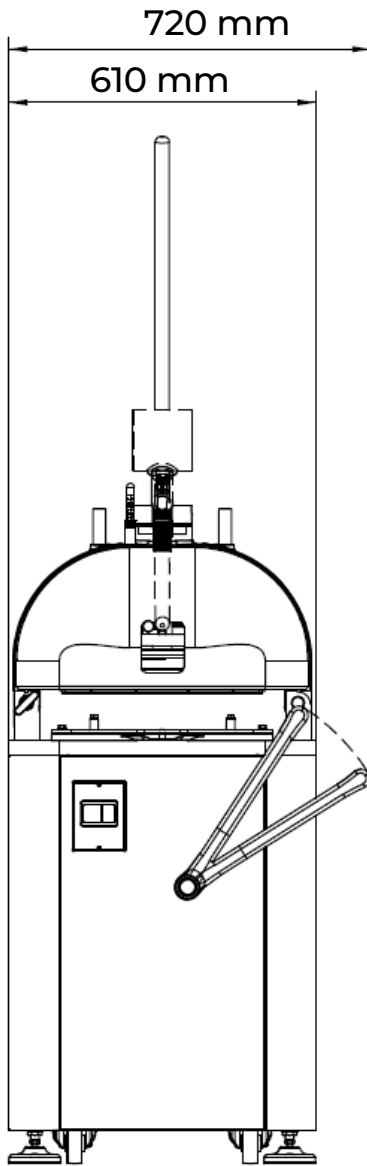

We reserve the right to alter specifications without notice.



1800 183 818

support@thegoodlady.com.au

www.thegoodlady.com.au