

Product Information

- This unit is designed to be installed into a cut-out in a new or existing bench top
- Wet or dry operation (temperature varies greatly when run dry, should not be left unattended for long periods of time)
- Temperature regulation via digital control, designed to hold product between 65°C - 90°C.
- Air insulated, double skinned tank for energy efficient heating
- Robust 304 grade stainless steel construction
- Manual fill and manual empty, valve operated waste
- 1/1 GN sized well, fits pans up to 150mm deep (sold separately). Supplied with pan dividers
- **12-month parts and labour warranty**



Specifications

Model	CH.BM.D.3
W x D x H (mm)	1137 x 647 x 284
Cutout Dimensions (mm)	1115 x 625
Total Connected Load	2.25kW
Electrical Connection	1Ø+N+E 240VAC / 50Hz (Onsite connection)
Water Connection	G 1/2" BSP
Waste Connection	1 1/4" BSP

Optional Extras

Radius Well	
Add R to code after the D	CH.BM.DR.3
Note: Radius Well must be nominated at time of order	

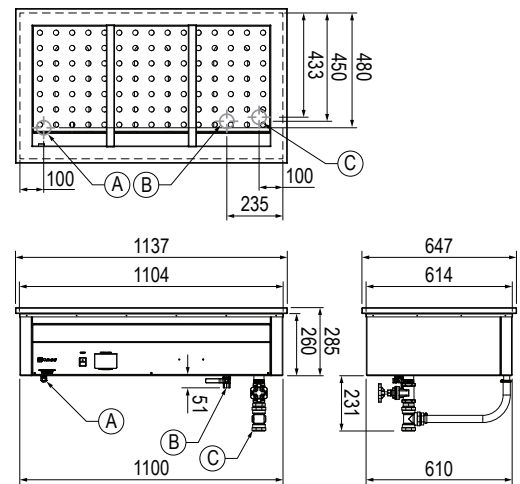

Accessories

Large Pan Dividers (To suit large GN pans)	CA.PXL
Cross Pan Dividers (To suit smaller GN pans)	CA.PXS

Legend

- A** Electrical Connection
- B** Water Connection
- C** Waste Connection

